

# Nussbaum

## AUTOMOTIVE LIFTS

 **HyperFlow®**



### JUMBO HF 7000 SCISSOR LIFT

### OWNERS / INSTALLATION MANUAL

ISSUE 4 USA

6/5/20

**PROUDLY**  
**MADE IN USA**



Lift Manufacturer:  
Nussbaum Automotive Solutions, LP

1932 Jordache Court  
Gastonia, North Carolina 28052

**This Lift and Guide belongs to the owner(s):**

---

---

---

---

## TABLE OF CONTENTS

<b>1. LIFT PURPOSE</b>	<b>4</b>
<b>2. LIABILITY</b>	<b>4</b>
<b>3. OWNER/EMPLOYER RESPONSIBILITIES</b>	<b>4-5</b>
3.1. ADDITIONAL OWNER/EMPLOYER RESPONSIBILITIES	6
<b>4. LIFT OPERATOR RESPONSIBILITIES</b>	<b>6</b>
<b>5. SAFETY REGULATIONS</b>	<b>6-7</b>
<b>OPERATING INSTRUCTIONS</b>	<b>9</b>
5.1. TO LOAD VEHICLE	9
5.2. TO LIFT VEHICLE	9-10
5.3. TO LOWER AND UNLOAD VEHICLE	10
<b>6. INSPECTION AND MAINTENANCE PLAN</b>	<b>11</b>
6.1. HOW OFTEN MUST THE LIFT BE CLEANED?	11
6.1.1. DAILY MAINTENANCE	11
6.1.2. YEARLY MAINTENANCE	12
6.2. LIFT MAINTENANCE	13
<b>7. TECHNICAL INFORMATION</b>	<b>14</b>
<b>8. TROUBLESHOOTING</b>	<b>15</b>
<b>9. FILL AND VENT THE HYDRAULIC SYSTEMS</b>	<b>16</b>
<b>10. INSTALLATION AND INITIATION</b>	<b>16</b>
10.1. SAFETY CHECKS	166
10.2. PREPARE LIFT ASSEMBLY LOCATION	17
10.3. INSTALLATION WITH DRIVE THROUGH DOOR	17
10.4. INSTALLATION ON AN INTERIOR BAY WITH EXISTING LIFTS	17
10.5. ESTABLISHING FRONT OR REAR PLATFORM GUIDELINES	18
<b>11. LIFT INSTALLATION</b>	<b>19</b>
11.1. UNPACK CONTAINER AND LOCATE ALL PIECES (FIGURES 7 & 8)	19
11.2. POSITION CONTROL STATION & PLATFORMS	20-21
11.3. MOUNTING THE PLATFORM, CONTROL STATION AND HOSE COVERS	22
11.4. ATTACHING PLATFORM EXTENSIONS	23
11.6. BLEEDING AND EQUALIZATION OF THE LIFT	24
<b>12. FINAL INSTALLATION CHECKOUT INSTRUCTIONS</b>	<b>24-25</b>
<b>13. REGULAR INSTALLATION CHECKOUT INSTRUCTIONS</b>	<b>26</b>
<b>APPENDIX 1: FLOOR PLAN</b>	<b>27</b>
1.1. 1. CONCRETE REQUIREMENTS	27
<b>APPENDIX 2: LIFT DIMENSIONS</b>	<b>28</b>
<b>APPENDIX 3: CONCRETE ANCHOR SPECIFICATIONS</b>	<b>29</b>
<b>APPENDIX 4: HYDRAULIC DIAGRAM</b>	<b>30</b>
1. HYDRAULIC PARTS LIST	31
<b>APPENDIX 5: ELECTRICAL DIAGRAM-400-230 V 3-PHASE</b>	<b>32</b>
<b>APPENDIX 6: FLUSHMOUNT CONCRETE PIT DRAWING</b>	<b>33</b>
<b>APPENDIX 6: FLUSHMOUNT INSTALLATION DRAWING</b>	<b>34-35</b>

# 1. Lift Purpose

Nussbaum lifting systems are the result of over 35 years experience in the automotive lifting industry. The high quality and superior concept ensures reliability, a long lift lifetime, and a strong economic business solution for your automotive lifting needs. The JUMBO is a scissor lift with a lifting capacity of 7,000 pounds. The Lift features a powerful 4.0hp motor and hard-chromed cylinder sets.

# 2. Liability

To avoid unnecessary damage, injury or death, read all operating instructions carefully. **Nussbaum Automotive Solutions, LP is not liable for any damages, injuries, or deaths resulting from misuse of the Lift. The user carries the risk alone.**

There will be no guarantee or liability for incidents involving injuries, death, or damage to equipment if these incidents are the result of one or more of the following:

- Inappropriate use of the Lift to include: Inappropriate installation, operation, and maintenance of the Lift.
- Use of the Lift while security devices are inoperative, not working properly, or are installed incorrectly.
- Failure to follow the operating instructions regarding transport, storage, installation, initiation, operation, and maintenance of the Lift.
- Unauthorized changes to the design and operation of the Lift.
- Wrong or incorrect maintenance practice.
- Catastrophes, acts of God, or external reasons.
- Nussbaum Lifts are warranted with the use of Nussbaum original or replacement parts. Use of unauthorized parts may void the warranty. For parts, call Nussbaum Automotive Solutions at 1-704-864-2470.
- It should be recognized that any piece of equipment can be dangerous when operated improperly.

# 3. Owner/Employer Responsibilities

## [AUTOMOTIVE LIFT INSTITUTE SAFETY REQUIREMENTS FOR OPERATION, INSPECTION AND MAINTENANCE \(ANSI/ALI ALOIM\)](#)

The Owner/Employer Must insure that lift operators are qualified and that they are trained in the safe use and operation of the lift: ALI/SM 93-1, ALI Lifting it Right safety manual; ALI/ST-90 ALI Safety Tips card; ANSI/ALI ALOIM-2000, American National Standard for Automotive Lifts-Safety Requirement for Operation, Inspection and Maintenance; ALI/WL Series, ALI Uniform Warning Label Decals/Placards; and in case of frame engaging lifts, ALI/LP-GUIDE, Vehicle Lifting Points/Quick Reference Guide for Frame Engaging Lifts and SAE J2184, Vehicle Lifting Points for Service Garage Lifting.

The Owner/Employer Must establish procedures to periodically inspect the lift in accordance with the lift manufacturer's instructions or ANSI/ALI ALOIM-2000, American National Standard for Automotive Lifts-Safety Requirements for Operation, Inspection and Maintenance; and the employer Must insure that the lift inspectors are qualified and that they are adequately trained in the inspection of the lift.

The Owner/Employer Must establish procedures to periodically maintain the lift in accordance with the lift manufacturer's instructions or ANSI/ALI ALOIM-2000, American National Standard for Automotive Lifts-Safety

JUMBO 7000 HF SCISSOR

Nussbaum Automotive Solutions, LP | 1932 Jordache Court, Gastonia, NC 28052 | 704.864.2470 | Email: [info@nussbaum-usa.com](mailto:info@nussbaum-usa.com) | [www.nussbaum-usa.com](http://www.nussbaum-usa.com)

Requirements for Operation, Inspection and Maintenance; and the employer Must insure that the lift maintenance personnel are qualified and that they are adequately trained in the maintenance of the lift.

The Owner/Employer Must maintain the periodic inspection and maintenance records recommended by the manufacturer or ANSI/ALI ALOIM-2000, American National Standard for Automotive Lifts-Safety Requirements for Operation, Inspection and Maintenance.

The Owner/Employer Must display the lift manufacturer's operating instructions; ALI/SM 93-1, ALI Lifting it Right safety manual; ALI/ST-90 ALI Safety Tips card; ANSI/ALI ALOIM-2000, American National Standard for Automotive Lifts-Safety Requirement for Operation, Inspection and Maintenance; ALI/WL Series, ALI Uniform Warning Label Decals/Placards; and in case of frame engaging lifts, ALI/LP-GUIDE, Vehicle Lifting Points/Quick Reference Guide for Frame Engaging Lifts; in a conspicuous location in the lift area convenient to the operator.

### **3.1. Additional Owner/Employer Responsibilities**

- Must require that Personal Protective Equipment (PPE) be used according to the appropriate regulations.
- Must display the "Safety Regulations" and adhere to them closely.
- Must ensure that all safety and danger signs on and around the Lift are observed and followed!
- Must follow the specified time intervals between the recommended inspection and maintenance procedures and tests.
- Must use only spare parts that comply with the technical requirements specified by the manufacturer.
- Must ensure that loose screws, nuts, and bolts are firmly tightened after maintenance.
- Must not modify the Lift without written consent of Nussbaum Automotive Solutions, LP.
- Must ensure that these instructions are maintained and available to all personnel that install, use, or maintain the lift. This document contains important information about installation, operation, and maintenance of the automotive Lift.
- Any changes to the installation and or location of the automotive Lift must be documented.

## 4. Lift Operator Responsibilities

- Must read and understand all safety and warning instructions in the manual or affixed to the lift.
- Must be trained to operate and use the Jumbo HF Lift for its designed use.
- Must be familiar with accident prevention and basic labor safety regulations.
- Must not allow unauthorized personnel to operate the Lift.

**Pay close attention to the danger and important information symbols shown below. Carefully read all marked passages throughout this manual.**

	<b><i>Danger! This sign indicates danger to life. Improper handling of the described operation may cause serious injury or death.</i></b>
---	---

	<b><i>Caution! This sign warns against possible damage to the automotive Lift or other material defects in case of improper handling.</i></b>
---	---

	<b><i>Attention! This sign indicates an important function or note.</i></b>
---	---

## 5. Safety Regulations

	<b><i>Danger! The Safety Regulations must be observed and strictly adhered to while working with the automotive Lift. Read the safety regulations and the ANSI/ALI ALOIM manual included with the lift documentation carefully before working with the Lift!</i></b>
---	--

### 1. IMPORTANT SAFETY INSTRUCTIONS – READ ALL INSTRUCTIONS

- The total weight of the lifted vehicle must not exceed 7,000 pounds.
- The Lift must not be installed in a hazardous location or in washing bays.
- The Lift must be checked by a service technician after initial installation and after repairs or changes have been made to the Lift.
- The operating and maintenance instructions must be followed while working with the Lift.
- High density blocks must be positioned correctly.
- Pre-check low clearance or specially equipped vehicles for ample clearance to avoid damage to the vehicle and/or Lift.
- Only trained personnel are to operate the Lift.
- No one is to stand within the working area (danger area) during vehicle lifting and lowering operations.
- No one is to occupy a vehicle during any phase of Lift operation.
- No one is to climb onto the automotive Lift when in a raised position.

- The main electrical switch (when applicable) must be switched off and locked out/tagged out according to OSHA Regulations before maintenance or repair work is performed on the Lift.
- The operator must continue to observe the vehicle and Lift throughout the lifting or lowering operation.
- Check the center of gravity of the vehicle if heavy parts, such as the engine are removed.
- If heavy parts such as the engine must be removed, the center of gravity will change. Secure the vehicle before removing parts to avoid the possibility of the vehicle becoming insecure.
- **Read all instructions** before operating lift.
- Care must be taken as burns may occur from touching hot parts.
- Do not operate the equipment with a damaged cord or if the equipment has been damaged – until it has been examined by a qualified service person.
- To reduce the risk of fire, do not operate equipment near open containers of flammable liquids (gasoline).
- Adequate ventilation should be provided when working on operating internal combustion engines.
- Keep hair, loose clothing, fingers, and all parts of body away from moving parts.
- Use only as described in this manual. Use only manufacturer’s recommended attachments.
- ALWAYS WEAR SAFETY GLASSES. Everyday eyeglasses only have impact resistant lenses, they are not safety glasses.

SAVE THESE INSTRUCTIONS

## 2. SAFETY DEVICES

***Nussbaum has designed several safety features into each Lift to ensure safe and efficient operations under a variety of conditions. Warranties will be voided, and dangerous working conditions exist if any of the listed devices are altered or disabled.***

Pressure relief valve	Safety device to prevent over pressuring of the hydraulic system.
Two independent master-slave systems	Safety device that protects against unintentional lowering.
Safety Ratchets	Safety device against unintentional lowering.
Hydraulic Flow Restrictors	Safety device to prevent excessive lowering speed.
Check Valve	Secures the vehicle against unauthorized lowering.
Hold-to-run controls	Safety device that protects against unsupervised operation

## SAFETY LABELS AFFIXED TO LIFT







### SAFETY WARNING LABELS FOR HINGED FRAME ENGAGING LIFTS

#### Lift Owner/User Responsibilities:

- A. This Safety Warning placard **SHALL** be displayed in a conspicuous location in the lift area.
- B. Use one of the mounting arrangements illustrated on back of this placard.
- C. These Safety Warning labels supplement other documents supplied with the lift.
- D. Be certain all lift operators read and understand these labels, operating instructions and other safety related information supplied with the lift.

<b>WARNING</b>	<b>WARNING</b>	<b>WARNING</b>
		
Position vehicle with center of gravity midway between adapters. ©	Remain clear of lift when raising or lowering vehicle. ©	Keep feet clear of lift while lowering. ©
<b>WARNING</b>	<b>WARNING</b>	<b>WARNING</b>
		
Clear area if vehicle is in danger of falling. ©	Avoid excessive rocking of vehicle while on lift. ©	Keep clear of pinch points when lift is moving. ©

www.autolift.org

<b>CAUTION</b>	<b>CAUTION</b>	<b>Power Unit: Apply labels near lift controls.</b>  <b>Lift Control Console: Apply labels in an accessible location.</b> 
		
Lift to be used by trained operator only. ©	Always use safety stands when removing or installing heavy components. ©	The messages and pictographs shown are generic in nature and are meant to generally represent hazards common to all automotive lifts regardless of specific style. Funding for the development and validation of these labels was provided by the Automotive Lift Institute, PO Box 88 Cortland, NY 13845. Replacement label sets may be obtained from the original lift manufacturer and ALI's member companies. They are protected by copyright. www.autolift.org © 2012 by ALI, Inc. ALIWL3300
<b>CAUTION</b>	<b>CAUTION</b>	
		
Authorized personnel only in lift area. ©	Use vehicle manufacturer's lift points. ©	

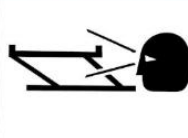
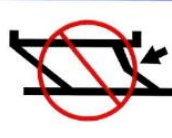
<b>NOTICE</b>	<b>NOTICE</b>	<b>NOTICE</b>
		
Read operating and safety manuals before using lift. ©	Proper maintenance and inspection is necessary for safe operation. ©	Do not operate a damaged lift. ©

SAFETY INSTRUCTIONS

If attachments, accessories or configuration modifying components that are located in the load path, affect operation of the lift, affect the lift electrical listing or affect intended vehicle accommodation are used on this lift and, if they are not certified for use on this lift, then the certification of this lift shall become null and void. Contact the participant for information pertaining to certified attachments, accessories or configuration modifying components.

www.autolift.org
©2007 by ALI, Inc.
ALI / WLSIAO1

READ ALL LABELS AND VERIFY THAT ALL AUTHORIZED USERS FULLY UNDERSTAND THE MEANING OF EACH CAUTION / WARNING / SAFETY INSTRUCTION. DO NOT REMOVE OR DEFACE SAFETY LABELS FROM THE LIFT.



# Operating Instructions



**DANGER! READ ALL OWNER'S MANUAL INSTRUCTIONS AND ANSI/ALI ALOIM BEFORE USING THE LIFT**

## 5.1. To Load Vehicle



**Danger! The operating instructions must be followed when operating the lift.**

Clear **persons and objects** from Lift working area.

Ensure the lifting **platforms** are in the lowest position.

Ensure **ramps** are released and in the down position, suitable for driving.

Drive the **vehicle** over the platforms and park in the center of the lifting area.

Secure the **vehicle** from rolling, put into gear, and apply the **parking brake**.

Check all the **danger points** of the Lift to ensure that loose objects or people are clear from Lift and working area.



**The manufacturer's service garage Lift points may be marked on the undercarriage of the vehicle with triangle shaped markings. If the Lift points are not marked on the vehicle, refer to the vehicle manufacturer for the approved Lift points.**



**The Center of Gravity must be located slightly towards the front of the lifting platforms. (Hose Side)**

Determine the **center of gravity**. Place the **High Density Blocks** in a position which assures equal contact with the **Lift Platforms** and the vehicle lifting points.

Check all the **danger points** of the Lift to ensure that loose objects or people are clear from Lift and working area.



**Modified or specialty vehicles: Contact vehicle manufacturer to determine if vehicle can be lifted on a hinged-pad frame engaging Lift.**

## 5.2. To Lift Vehicle

- Drive the vehicle over the lifting platforms (long axis) of the lift stopping after the front tires clear the front extensions. Make certain the vehicle is centered on the lift from side to side.
- The vehicle must be prevented from rolling by blocking, setting brakes or engaging the transmission.



**Danger! If the vehicles wheelbase is too short and the wheels remain on the platform extensions, you must remove the ramps before lifting the vehicle.**

- If the main platforms are not capable of reaching the vehicle pick-up points, the platform extensions should be raised even with the platforms and their supports extended from beneath the platforms.

- Verify the **vehicle** is properly centered on the Lift and **all pads** are properly positioned on the manufacturer approved lift points of the vehicle.



**Danger! The platform extensions support must be completely engaged or the vehicle could suddenly fall.**

- Position the “High Density Blocks” under the pick-up points of the vehicle as described by the vehicle manufacturer.



**Danger! The blocks must be positioned in a safe and secure manner or the vehicle could slip and fall from the lift. Always place blocks flat, not on the narrow edges.**

- Be certain that no bystanders are in or around the vehicle before lifting.
- Lift up and Push the handle FORWARD (Fig. 1) until the blocks engage the frame.
- Once the wheels clear the ground, ensure the vehicle is safely positioned by a generous shaking. If the vehicle appears unstable, lower the vehicle, and reposition.
- Lift up and Push the handle FORWARD (Fig. 1) to raise the vehicle to the desired working height making certain that no bystanders are in or around vehicle during the entire process.

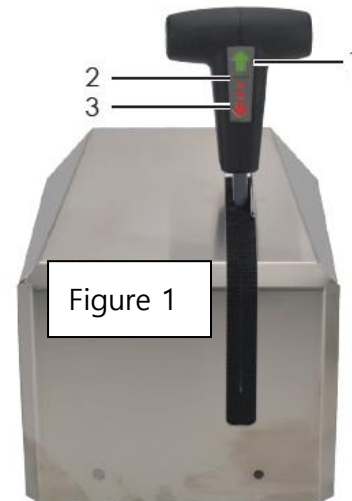

### 5.3. To Lower and unload Vehicle





**Danger! When lowering the lift absolute care must be taken to ensure that there are no objects or bystanders in the area in which the lift and vehicle are to be lowered.**

- Lift up and Pull the handle DOWNWARD to lower the vehicle. The further down the handle is pulled, the faster the vehicle will descend.
- Release the handle (Fig. 1) when the vehicle has reached the appropriate working height or has reached its lowest possible position.
- Observe the entire lowering process and control the area to ensure bystanders or objects to not enter the area of the lowering vehicle.
- When the lift is in its lowest position remove the “High Density Blocks”.
- If platform extensions have been used for support, lift them and slide all support devices back into their original positions under the platforms.
- Drive the vehicle off the lift.

# SAVE THESE INSTRUCTIONS

## 6. Inspection and Maintenance Plan

	<i>Attention! Before conducting maintenance work, safety precautions must be in place to eliminate harm to people working with or around the Lift.</i>
	<i>Danger! To avoid personal injury, allow only qualified technicians to perform maintenance on the Lift.</i>

To guarantee the utmost availability and to ensure that the Lift remains functional, maintenance work contracts are organized between our clients and their local retailers.

Service must be performed at regular intervals of **3 months** in accordance with service manual. Proof of maintenance records may be a prerequisite for warranty claims. The maintenance rate must be increased if the Lift is in continuous operation, in a dirty environment, or in contact with de-icing salts, sand, pebble stones, natural soil, and industrial dust of all manner, water, or constant humidity caused by insufficient ventilation. During daily operation, the Lift must be closely observed to ensure that it is functioning correctly. In the case of malfunction or fluid leak, Technical Service must be informed.

### 6.1. How often must the Lift be cleaned?

The schedule depends on the cleanness of the workshop and location of the Lift. The degree may vary dependent on the season, weather conditions, and the ventilation of the workshop. The best protection for the Lift is a regular cleaning every month. Under bad conditions, it may be necessary to clean the Lift every week.

#### 6.1.1. Daily Maintenance

- Clean the Lift and the floor with a mild, non-abrasive detergent.
- Remove dirt with a sponge, or if necessary, a soft brush.
- Rinse away detergent with sponge.
- Do not leave any kind of liquid on machine.
- Check for proper operation after any power failure, or flooding of the lift of any type.
- Perform equalization procedure if platforms become unlevel. (See Sec 12.7)
- Check for leaking fluid from pump, hoses, tubes, or cylinders.
- Prevent corrosion by oiling metallic surfaces and retouching paint.
- Lubricate all fittings with high pressure grease.
- Check condition of “High Density Blocks” and replace if worn.

- During winter months in “snow belt” areas great care should be taken to keep the lift as free from corrosive ice/snow melting agents as possible.
- Examine locking mechanism, checking for any stress cracks and proper function of pneumatic cylinders.

	<p><b><i>Danger! Never use any type of pressure or steam cleaning devices on the lift. Damage to the seals and hoses could occur causing failure of the hydraulic system.</i></b></p>
---	---

## 6.1.2. Yearly Maintenance

- Safety Related
- Check for proper function of all mechanical and hydraulic locking functions.
- Check for proper anchoring to the floor.
- Check for floor stability. (no cracking)
- Check for potential structural failure particularly in welded areas.
- Check for bending or distortion of mechanical parts.
- Replace safety related parts if there is any doubt about the ability to perform their function
- Replace hydraulic fluid with AW light 150 ISO32 or equivalent.
- Maintenance Related
- Check for any hydraulic leaks and condition of tubes and hoses.
- Check electrical connections, switches and fuses.
- Check for wear on bearings, hinge points and shafts.
- Check for condition of all lifting pads.
- Check for corrosion.
- Replace any worn or improperly functioning part before breakdown occurs to save future service charges and down time.
- Replace hydraulic hoses every 6 years.

	<p><b><i>Danger! Before beginning any maintenance work: Locate the power supply main switch and turn off. Lockout and tag out to prevent re-energizing system during maintenance. Secure the danger area around the Lift and secure the Lift with safety stands to guards against unintentional lowering.</i></b></p>
---	---

Inspection, repair and maintenance must be performed by a certified Nussbaum technician who has been trained on the lift they are servicing. They must be able to make proper judgment as to the repair or maintenance that needs performed to ensure full safety, operational reliability and structural integrity during the lifetime of the lift. Proper maintenance records should be kept to back up possible warranty claims.

## 6.2. Lift Maintenance

PART	ACTION/PRODUCT
Clean the Piston-Rod.	Use compressed air.
Check Oil Level.	Fill the tank with a clean, high quality AW32 oil.
Change the hydraulic oil at least once a year.	To change the oil, lower the Lift to its lowest position. Empty tank and refill with clean oil. Approximately 2 Gallons (If ambient temperature is under 40 degrees Fahrenheit, use lower than 32 viscosity). Dispose of used oil according to the appropriate regulations.
Check all welded joints for cracks.	If any cracks are found on the Lift, stop use immediately. Switch-off and secure the power supply and call service provider.
Check all external surfaces for damage.	If damaged, repair immediately. If repairs are not made immediately, permanent damage to the powder-coated surface may result. Repair and clean damaged areas with an abrasive paper (120 grit). Coat repaired area with a suitable paint (observe the RAL Number).
Check Zinc Surface. White rust can result from moisture laying in certain areas for long periods of time or poor ventilation. Poor ventilation can also result in rust formation. Rust may result from mechanical damage, wear, aggressive sediments (de-icing salt, liquids), or insufficient cleaning.	Repair and clean these areas with abrasive paper (240 grit). Coat repaired area with a suitable paint (observe the RAL Number).
Check all safety devices.	All safety devices must be in good working condition. If not, contact Technical Service.

### REPLACEMENT PARTS

ONLY USE NUSSBAUM ORIGINAL EQUIPMENT PARTS TO REPAIR THE LIFT

CALL NUSSBAUM PARTS DEPARTMENT AT 1-704-864-2470

## 7. Technical Information

TECHNICAL RATINGS	TECHNICAL INFORMATION
Lifting Capacity	7,000 lbs
Load Distribution	3,500 lbs per platform
Lifting Time	approximately 40 seconds
Lowering Time	approximately 30 seconds
Line Voltage	208-240 volt, 60 Hz, 30 amp, single phase
Lifting Height	78.5" (standard height model)
Power Rating	4 HP (2.98 Kw)
Circuit Breaker Requirement	30 Amp min.
Motor Speed	3450 rpm
Hydraulic Pressure	Approximately 3000 PSI (207 bar)
Pressure Relief Valve	Approximately 4250 PSI (293 bar)
Oil Tank Capacity	2 gallons (7.5 Liters)
Sound level	≤ 75 dBA

## 8. Troubleshooting

If the Lift does not work properly, refer to the following troubleshooting guide. If the problem cannot be resolved, call Technical Service at 704.864.2470.

PROBLEM	POTENTIAL CAUSE	REPAIR OPTIONS
Motor does not start	No power supply, or feed line is cut	Check the power supply at the facility breaker box and the power supply box.
	Thermal protector in the motor is activated	Let the motor cool for 10 minutes and switch it on
	Internal contactor is defective	Call technical service.
Motor starts, Lift does not move	Motor is defective	Call technical service.
	Vehicle is too heavy	Check vehicle for empty weight. Unload unnecessary weight from vehicle. The lift can raise a weight up to 7000lbs.
	Oil level is too low	Lower Lift and fill oil reservoir. Check for leakage. Call Technical Service if leakage is observed.  Refill the oil if necessary with AW light 150 ISO32 hydraulic fluid or equivalent.
	Hydraulic pump is defective	Call Technical Service.
	Coupling between motor and pump is defective	Call Technical Service.
	Pressure line leaking	Call Technical Service.
The Lift will not lower	Pressure relief valve is defective	Call Technical Service.
	Cylinder is defective	Call Technical Service.
	An obstacle is restricting the Lift from being lowered	Press the Raise Button until the obstacle is freed. Remove the obstacle.
The Lift lowers unexpectedly	Operating lever is defective	Call Technical Service.
	Lowering valve is defective	Call Technical Service.
	Lowering valve is defective	Call Technical Service.

### REPLACEMENT PARTS



ONLY USE NUSSBAUM ORIGINAL EQUIPMENT PARTS TO REPAIR THE LIFT

CALL NUSSBAUM PARTS DEPARTMENT AT 1-704-864-2470

## 9. Fill and Vent the Hydraulic Systems

The lift is preinstalled at the factory and is delivered with the hoses connected to the unit. After unpacking the power unit, loosen the allen head screws to remove the back cover and fill the power unit with a high-quality hydraulic oil with a viscosity of AW32. The required oil volume is approximately 2 gallons. After filling, the oil must be near the top of the oil dipstick or to the “fill” line.

- Make certain the lift area is free of all bystanders.
- Check all hose connections for tightness, most leaks occur at connection points



	<b><i>Danger! The lift is pre-tested at the factory, so the hoses and cylinders are already full of oil. Over-filling the system before bleeding and lowering can cause the tank to overflow due to the excess fluid.</i></b>
	<b><i>This procedure must always be completely carried out, meaning first fill and then vent. This is the only method of balancing a lift with HyperFlow</i></b>

## 10. Installation and Initiation

### 10.1. Safety Checks

**The safety check is necessary to guarantee safe operation of the Lift during use.**

Safety checks should occur as follows: after installation, before initial startup, after initial startup, at least once a year, and any time modifications have been made to the Lift.

	<b><i>Danger! Before the installation of the Lift, secure the installation area to prevent access by unauthorized persons.</i></b>
	<b><i>Attention! Before beginning installation, familiarize yourself with the entire installation process and with the “Foundation Plan” (Appendix 1).</i></b>

#### A. TOOLS NEEDED FOR THE INSTALLATION

- Chalk line
- Marking Pen
- Tape Measure
- 4' Level
- Hacksaw
- Hammer Drill
- ½" & ¼" Masonry Bits
- Metric Hex Key Set
- Hammer
- SAE Wrench Set
- Transmission funnel



## B. SUPPLIES NEEDED FOR INSTALLATION

- 12 ½" x 6-½" concrete anchors
- 10 ¼" x 3" concrete anchors
- 2 gallons AW32 light hydraulic fluid or equivalent.

## 10.2. Prepare Lift Assembly Location

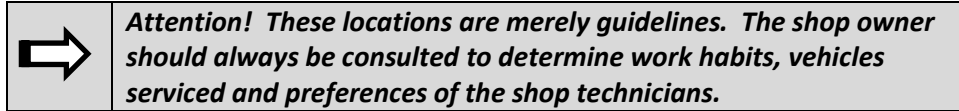

The installation of the Lift is performed by manufacturer trained technicians or by the manufacturer's distribution partner. The Lift owner may use their trained mechanics to install the Lift. The installation must be performed according to the following regulations:

- Use architectural plans, if available, to determine Lift location.
- Lift is intended for indoor installation only. Installation in an outdoor application is prohibited and will void the warranties of the product.
- Always consult a qualified person regarding local regulations for seismic requirements.
- Do not install Lift in hazardous locations, depression areas, or washing stalls.
- Concrete must have compression strength of at least 3,500PSI and be a minimum of 4 inches thick.
- Mount on a level foundation.
- Mount on a foundation deeper than the local external frost line.
- Be sure to read the ANSI/ALI ALIS prior to installation.

## 10.3. INSTALLATION WITH DRIVE THROUGH DOOR

- Determine door or bay width. (measurement W) (Fig.2)
- Determine center of door and mark. (measurement  $W \div 2$ )
- Multiply the door width by 1.5 ( $W \times 1.5$ ) and draw arcs with a tape measure from the door towards the center of the bay as shown. (Fig. 2)
- Be sure to use the same location from each side of the door!
- Place a mark at the intersection of the two arcs.
- Snap a chalk line from the intersection of the arcs to the center point of the door. This is the "Bay Center Line".

## 10.4. INSTALLATION ON AN INTERIOR BAY WITH EXISTING LIFTS

- Determine the distance between lifts in the opposing bays. (measurement W) (Fig. 3)
- Determine the center of those lifts and mark. (measurement  $W \div 2$ )
- Multiply the width between existing lifts by 1.5 ( $W \times 1.5$ ) and using tape measure draw arcs from each opposing lift towards the center of the bay as shown in figure 3. **Be sure to use the same location from each of the opposing lifts!**

- Place a mark at the intersection of the two arcs.
- Snap a chalk line from the intersection of the arcs to the center point of the existing lifts. This is the “Bay Center Line”

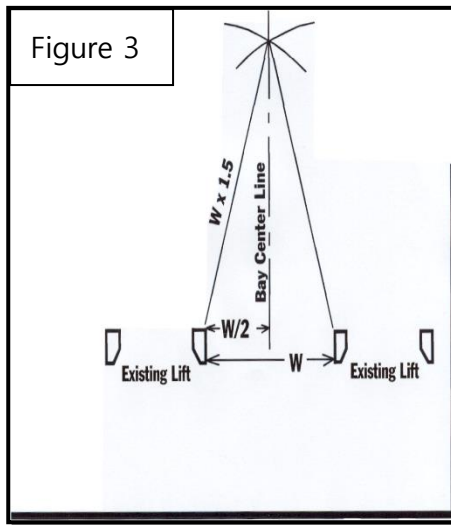
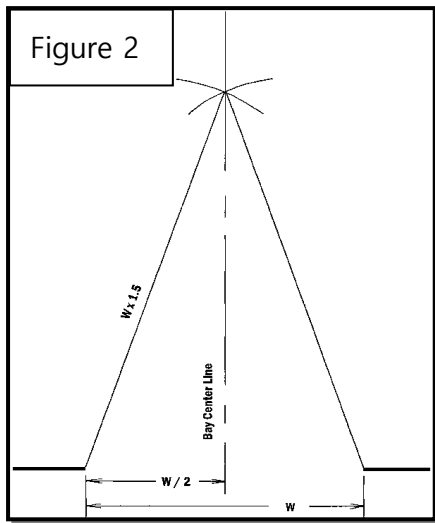

## 10.5. ESTABLISHING FRONT OR REAR PLATFORM GUIDELINES

**Establishing location from the Lift Front.** Allow 2’ (600mm) for a workbench, 3’ (920mm) for working area and an additional 6’ (1830mm) for the front of the car. This is a total of 11’ (3350mm) from the wall to the front of the lift platform (excluding ramps). (Fig. 4)

**Establishing location from the Lift Rear.** Allow 10’ (3050mm) from the inside of the door to the rear of the platform (excluding ramps) (Fig. 4)

- Determine the best method above for your application a place a mark on the “Bay Center Line” at the appropriate location.
- Measure 4’ (1200mm) down the “Bay Center Line” and place a mark at that point. (Fig. 4)
- From that mark (established in 5.3.12) draw two, 5’ (1500mm) arcs with the tape measure approximately 3’ (900mm) on both sides of the “Bay Center Line” (Fig. 4)

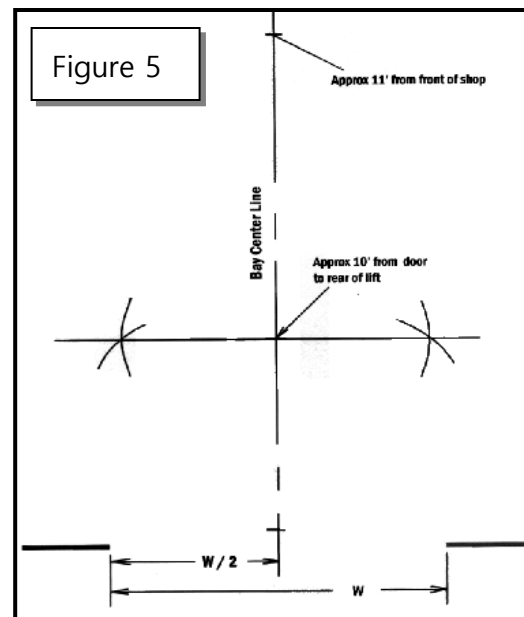
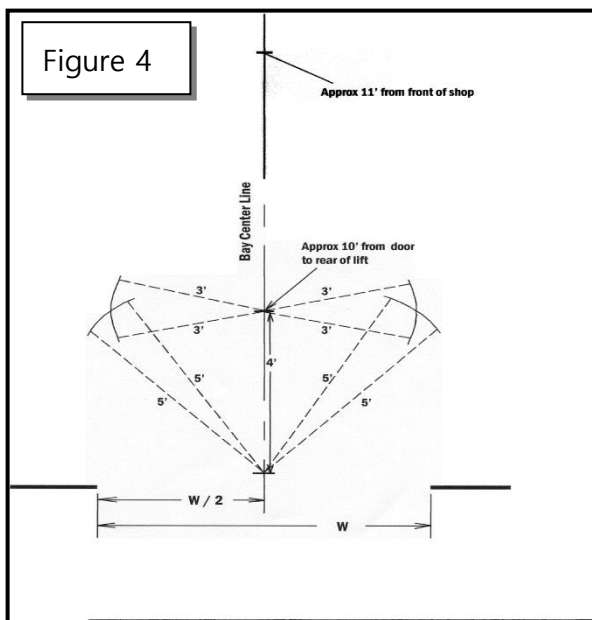

JUMBO 7000 HF SCISSOR

- From the mark establishing either the rear or front location of the platforms (whichever method used) draw two, 3' (900mm) arcs with the tape measure that intersect the 5' (1500mm) arcs (created in 5.3.13). (Fig. 4)
- Make marks at each of the intersections created by the arcs.
- Snap a line connecting each of the marks (created in 5.3.15) This becomes the rear or front guideline for the platforms. (Fig. 5)
- Measure 15 ¾" on both sides of the "Bay Center Line" in two locations, mark and snap two additional lines. These lines should run parallel with each other and be exactly 31.5 inches apart. (Fig. 6) These lines become the inner platform base guidelines.
- For express lube and pickup lifting purposes, the platforms may be distanced by 23"-31.5"

**This procedure establishes the location for the exact placement of the lift.**

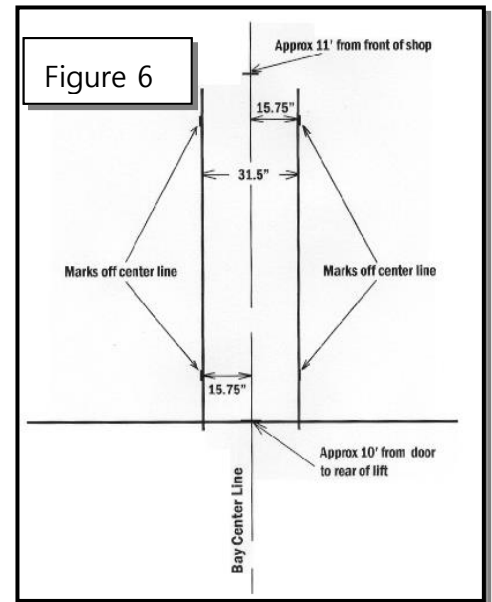

## 11. LIFT INSTALLATION

### 11.1. Unpack container and locate all pieces (Figures 7 & 8)

Part	Quantity
Owner/Installation Manual	1
Hose Covers (left, right, control)	3
Main Control Station	1
Lifting Platforms	2
High density blocks	8(4 Large, 4 Small)
Hydraulic Hoses	1(Connected)
Platform Extensions	4
Platform Extension Bolts	8

 **Attention! Report any shortages immediately**



Figure 7

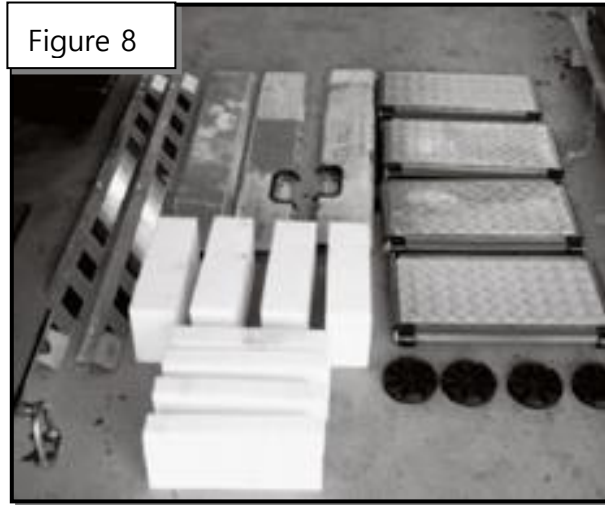



Figure 8

## 11.2. POSITION CONTROL STATION & PLATFORMS

- Front of the lift is the end with the hydraulic hoses
- Control station can be mounted of either the driver or passenger side of the lift.
- Figure 7 shows the packing of the lift. The passenger side platform is on the bottom beneath the driver side platform. The control station is on top.
- Set the control station on the appropriate side of the lift for application. (Fig. 9)

 **Attention! Position the pour spout at the top of the container when pouring. This will eliminate the “glugging” effect.**

- Remove top of control panel
- At this point, a qualified electrician should connect the electrical power to the control station (Appendix 5)
- Turn “Main Power Switch” on control station (if applicable) to the ON position.
- Operate the “Lifting” handle (Fig. 1) and raise the lift approximately 48” (1220mm) Raising the lift makes it easier to position.

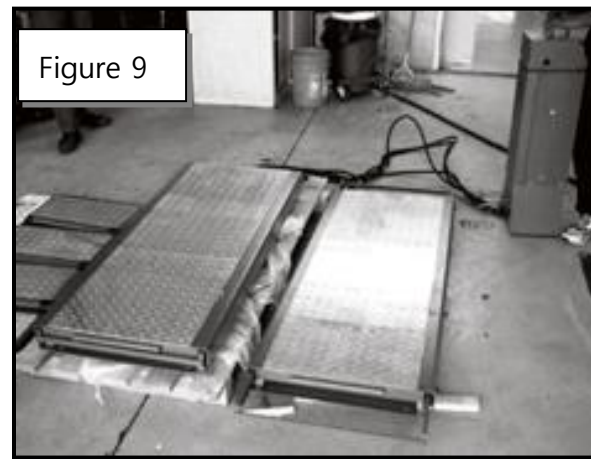

Figure 9

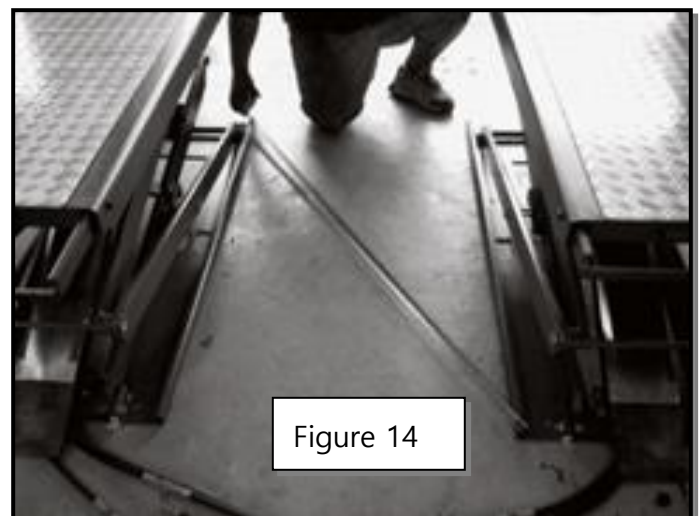
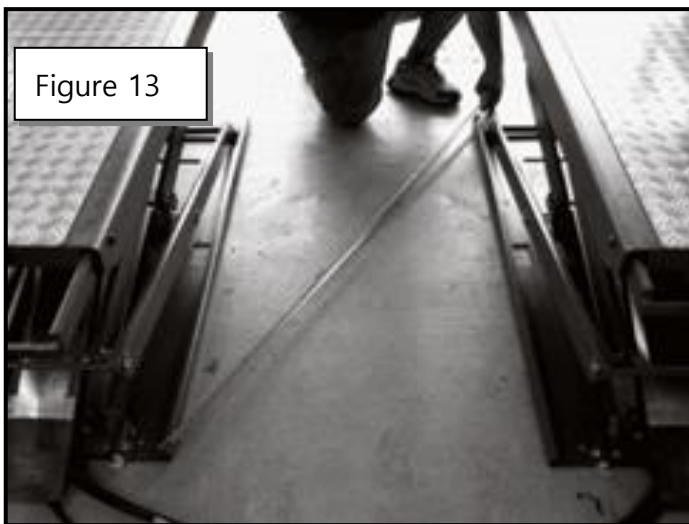
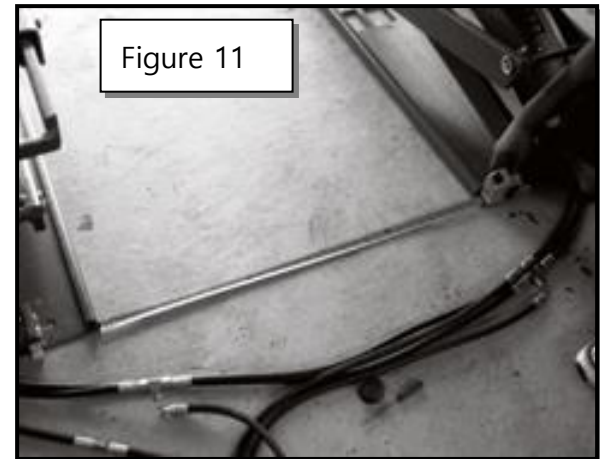

Figure 10



Always keep the lift area free of bystanders and objects whenever raising or lowering the lift.

- Position each runway on the appropriate “inner platform line” (determined in Fig. 6) and on either the “ front or rear platform lines” (determined in Fig. 5)
- Measure between platforms for ensure there is 31½” (800mm) (Fig. 11)
- Locate left and right bottom hose covers. A cutout in each side will correspond to the hydraulic hoses on each platform. Attach each to “U” bracket located on the inner front side of each platform with appropriate machine screw and nut. (Figure 12)
- Notice “T” fittings in Figure 10. Loosen very slightly and point hoses towards control station and retighten.
- Check mating surfaces between platform baseplate and the concrete floor. There must be continuous contact between the baseplates and the floor. If not, shims or high-strength grout must be used.
- Recheck alignment of platforms with layout lines established earlier. Check for squareness of platforms by cross measuring between front left and right rear inner corners and then front right and left rear inner corners. (Figs. 13 & 14) Both measurements must be identical if the platforms are square.





### 11.3. MOUNTING THE PLATFORM, CONTROL STATION AND HOSE COVERS

- Drill ½" (12mm) mounting holes through their corresponding locations in the four corners and centers of each platform. To ensure the platforms do not move during the drilling process, insert an anchor after each hole is drilled. Make sure to clean all debris from holes before inserting anchors. (Fig. 15)

 **Drill the holes completely through concrete if possible. This will allow the anchors to be flush with the concrete and filled if the lift is ever moved to a new location**

- Lower the lift (moving an obstruction first) and straighten the hydraulic hoses in the bottom covers making absolutely certain they are not kinked, smashed or accidentally nicked during the drilling process. The "T" fittings can be slightly loosened during this process to help flatten the hoses in the cover.
- Making sure the left and right hose covers are straight, drill ¼" (6mm) holes into concrete through the corresponding locations in the cover bottoms. Insert anchors as the holes are drilled to prevent any potential movement.
- Locate the final position for the control station. If the hose cover is too long, it should be cut to length with a hacksaw. It should protrude approximately ½" (12mm) under the control station.

 **Any sharp edges on the cover bottom or top must be eliminated to prevent accidentally cutting one or more of the hydraulic hoses**

- Position the final hose cover bottom and drill ¼" (6mm) holes through corresponding locations. Insert anchors as the holes are drilled to prevent any potential movement. (Fig. 16)
- Position the control station in its final location and drill ¼" (6mm) holes through corresponding locations in the base (Fig. 17). Insert anchors as the holes are drilled to prevent any potential movement.
- Cycle lift through several up/down cycles observing all hydraulic hoses and fittings for leaks. If leaks are present, tighten fittings to eliminate. If leaks are still present, contact Nussbaum Technical Service.
- If no leaks are present install top hose covers on bottom hose cover plates (Fig. 18) and tighten nuts on anchors. Anchors protruding out from the nut should be cut off flush.



Figure 15

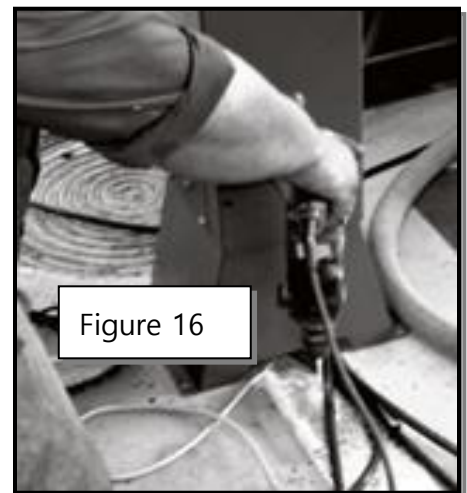

Figure 16

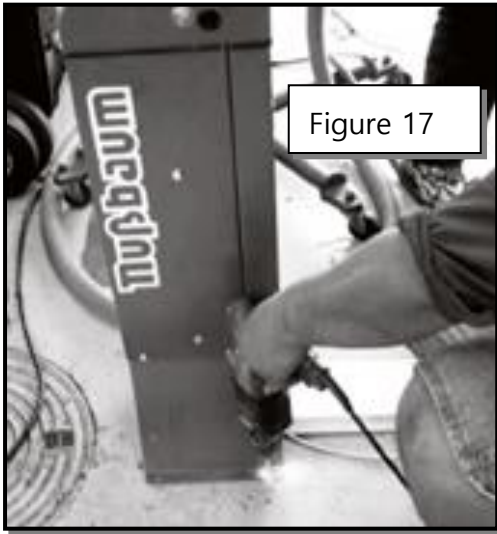

Figure 17

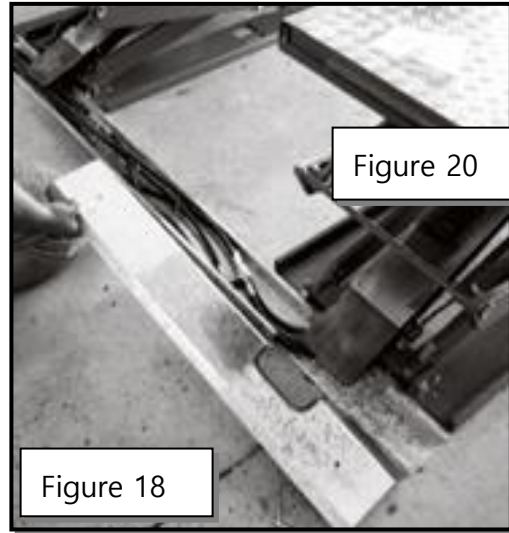

Figure 20

Figure 18

#### 11.4. ATTACHING PLATFORM EXTENSIONS

- Locate the (4) Platform Extensions and the (4) Platform Extension Rods.
- Align the holes on a Platform Extension with the holes at the end of a Platform.
- Insert the Platform Extension Attachment Rod through the holes from the outside of the lift. (Fig. 20)

 ***Slight pressure might be necessary. Lubrication should be used during this procedure***

- Extend the extension straight out (parallel with the top surface of the platform) and push the flat end of the Platform Extension Rod past the flange on the extension (inside) and then pivot it underneath the extension.
- Repeat the procedure for the remaining 3 extensions.

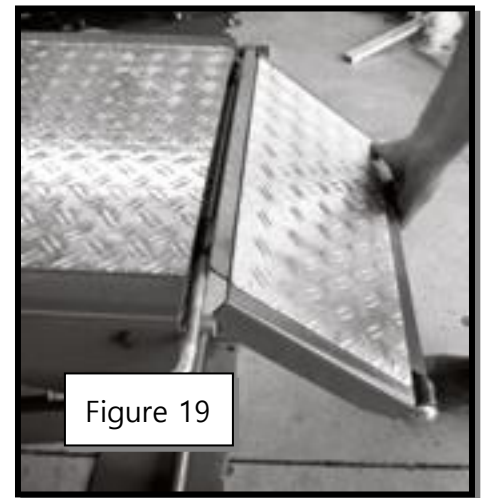
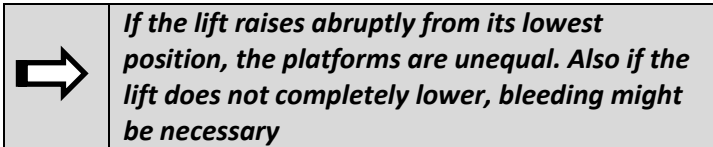

Figure 19

## 11.5. BLEEDING and EQUALIZATION OF THE LIFT



- Make sure there is no external leaking of hydraulic fluid.
- Use the handle to raise the lift to the highest position.
- Once the lift reaches the maximum height, continue allowing the motor to run for approximately 30 seconds, adding fluid if necessary.
- This allows the Hyperflow system to circulate all air back to the hydraulic reservoir!

## 12. Final Installation Checkout Instructions

1. *Review* Operation Instructions on pages 9-10.
2. *Perform* all steps as outlined in the Operation Instructions on pages 9-10.
3. *Verify* all operations function properly and securely.
4. *Demonstrate the operation of the lift to the owner/operator and review correct and safe lifting procedures using the ANSI/ALI Lifting It Right booklet as a guide.*
5. *Provide the complete lift documentation package to the owner for future reference.*
6. *Complete* the Manufacturer's Checklist below and *Review* with the Owner.
7. *Review* the terms of the warranty registration card.
8. *Complete and Return* the card along with a copy of the completed Manufacturer's Checklist to:

Nussbaum Automotive Solutions, LP  
1932 Jordache Court  
Gastonia, NC 28052

Fax: 1-704-864-2476

Email: [warranty@nussbaum-usa.com](mailto:warranty@nussbaum-usa.com)



### First security check before installation

 Filling out and leave in this manual

Serial-no.: \_\_\_\_\_

kind of check	all right	defect missing	verification	remark
Type plate.....	<input type="checkbox"/>	<input type="checkbox"/>	<input type="checkbox"/>	.....
Short operating instruction.....	<input type="checkbox"/>	<input type="checkbox"/>	<input type="checkbox"/>	.....
Warning designation.....	<input type="checkbox"/>	<input type="checkbox"/>	<input type="checkbox"/>	.....
Designation lifting/lowering.....	<input type="checkbox"/>	<input type="checkbox"/>	<input type="checkbox"/>	.....
Detailed operating instruction.....	<input type="checkbox"/>	<input type="checkbox"/>	<input type="checkbox"/>	.....
Main switch lockable.....	<input type="checkbox"/>	<input type="checkbox"/>	<input type="checkbox"/>	.....
Condition/Function foot protection.....	<input type="checkbox"/>	<input type="checkbox"/>	<input type="checkbox"/>	.....
Function button "Lifting/Lowering".....	<input type="checkbox"/>	<input type="checkbox"/>	<input type="checkbox"/>	.....
Condition/Function Ramps.....	<input type="checkbox"/>	<input type="checkbox"/>	<input type="checkbox"/>	.....
Condition automotive lift.....	<input type="checkbox"/>	<input type="checkbox"/>	<input type="checkbox"/>	.....
Securing of bolts.....	<input type="checkbox"/>	<input type="checkbox"/>	<input type="checkbox"/>	.....
Condition bolts and bearings.....	<input type="checkbox"/>	<input type="checkbox"/>	<input type="checkbox"/>	.....
Construction (deformation,cracking).....	<input type="checkbox"/>	<input type="checkbox"/>	<input type="checkbox"/>	.....
Torque of the dowels.....	<input type="checkbox"/>	<input type="checkbox"/>	<input type="checkbox"/>	.....
Fixed seat of the screws.....	<input type="checkbox"/>	<input type="checkbox"/>	<input type="checkbox"/>	.....
Condition operating unit.....	<input type="checkbox"/>	<input type="checkbox"/>	<input type="checkbox"/>	.....
Condition surface piston rod.....	<input type="checkbox"/>	<input type="checkbox"/>	<input type="checkbox"/>	.....
Condition coverings.....	<input type="checkbox"/>	<input type="checkbox"/>	<input type="checkbox"/>	.....
Condition electrical wires.....	<input type="checkbox"/>	<input type="checkbox"/>	<input type="checkbox"/>	.....
Level of hydraulic oil.....	<input type="checkbox"/>	<input type="checkbox"/>	<input type="checkbox"/>	.....
Condition of the hydraulic system.....	<input type="checkbox"/>	<input type="checkbox"/>	<input type="checkbox"/>	.....
Condition hydraulic hoses.....	<input type="checkbox"/>	<input type="checkbox"/>	<input type="checkbox"/>	.....
Function test with vehicle.....	<input type="checkbox"/>	<input type="checkbox"/>	<input type="checkbox"/>	.....
Function equalisation of the lift.....	<input type="checkbox"/>	<input type="checkbox"/>	<input type="checkbox"/>	.....
Condition polymer-supports.....	<input type="checkbox"/>	<input type="checkbox"/>	<input type="checkbox"/>	.....

( mark here applicable, in case of verification mark in addition to the first mark!)

Security check carried out:.....

Carried out the company:.....

Name, address of the competent:.....

Result of the Check:

- Initiation not permitted, verification necessary
- Initiation possible, repair failures until.....
- No failings, Initiation possible

.....  
signature of the expert

.....  
signature of the operator

If failures must be repaired:

Failures repaired at: .....signature of the operator

(Use another form for verification!)

### Regular security check

 *Filling out and leave in this manual*

Serial-no.: \_\_\_\_\_

kind of check	all right	defect missing	verification	remark
Type plate.....	<input type="checkbox"/>	<input type="checkbox"/>	<input type="checkbox"/>	.....
Short operating instruction.....	<input type="checkbox"/>	<input type="checkbox"/>	<input type="checkbox"/>	.....
Warning designation.....	<input type="checkbox"/>	<input type="checkbox"/>	<input type="checkbox"/>	.....
Designation lifting/lowering.....	<input type="checkbox"/>	<input type="checkbox"/>	<input type="checkbox"/>	.....
Detailed operating instruction.....	<input type="checkbox"/>	<input type="checkbox"/>	<input type="checkbox"/>	.....
Main switch lockable.....	<input type="checkbox"/>	<input type="checkbox"/>	<input type="checkbox"/>	.....
Condition/Function foot protection.....	<input type="checkbox"/>	<input type="checkbox"/>	<input type="checkbox"/>	.....
Function button "Lifting/Lowering".....	<input type="checkbox"/>	<input type="checkbox"/>	<input type="checkbox"/>	.....
Condition/Function Ramps.....	<input type="checkbox"/>	<input type="checkbox"/>	<input type="checkbox"/>	.....
Condition automotive lift.....	<input type="checkbox"/>	<input type="checkbox"/>	<input type="checkbox"/>	.....
Securing of bolts.....	<input type="checkbox"/>	<input type="checkbox"/>	<input type="checkbox"/>	.....
Condition bolts and bearings.....	<input type="checkbox"/>	<input type="checkbox"/>	<input type="checkbox"/>	.....
Construction (deformation,cracking).....	<input type="checkbox"/>	<input type="checkbox"/>	<input type="checkbox"/>	.....
Torque of the dowels.....	<input type="checkbox"/>	<input type="checkbox"/>	<input type="checkbox"/>	.....
Fixed seat of the screws.....	<input type="checkbox"/>	<input type="checkbox"/>	<input type="checkbox"/>	.....
Condition operating unit.....	<input type="checkbox"/>	<input type="checkbox"/>	<input type="checkbox"/>	.....
Condition surface piston rod.....	<input type="checkbox"/>	<input type="checkbox"/>	<input type="checkbox"/>	.....
Condition coverings.....	<input type="checkbox"/>	<input type="checkbox"/>	<input type="checkbox"/>	.....
Condition electrical wires.....	<input type="checkbox"/>	<input type="checkbox"/>	<input type="checkbox"/>	.....
Level of hydraulic oil.....	<input type="checkbox"/>	<input type="checkbox"/>	<input type="checkbox"/>	.....
Condition of the hydraulic system.....	<input type="checkbox"/>	<input type="checkbox"/>	<input type="checkbox"/>	.....
Condition hydraulic hoses.....	<input type="checkbox"/>	<input type="checkbox"/>	<input type="checkbox"/>	.....
Function test with vehicle.....	<input type="checkbox"/>	<input type="checkbox"/>	<input type="checkbox"/>	.....
Function equalisation of the lift.....	<input type="checkbox"/>	<input type="checkbox"/>	<input type="checkbox"/>	.....
Condition polymer-supports.....	<input type="checkbox"/>	<input type="checkbox"/>	<input type="checkbox"/>	.....

( mark here applicable, in case of verification mark in addition to the first mark!)

Security check carried out:.....

Carried out the company:.....

Name, address of the competent:.....

Result of the Check:

- Initiation not permitted, verification necessary
- Initiation possible, repair failures until.....
- No failings, Initiation possible

.....  
signature of the expert

.....  
signature of the operator

If failures must be repaired:

Failures repaired at: .....signature of the operator

(Use another form for verification!)

# APPENDIX 1: FLOOR PLAN

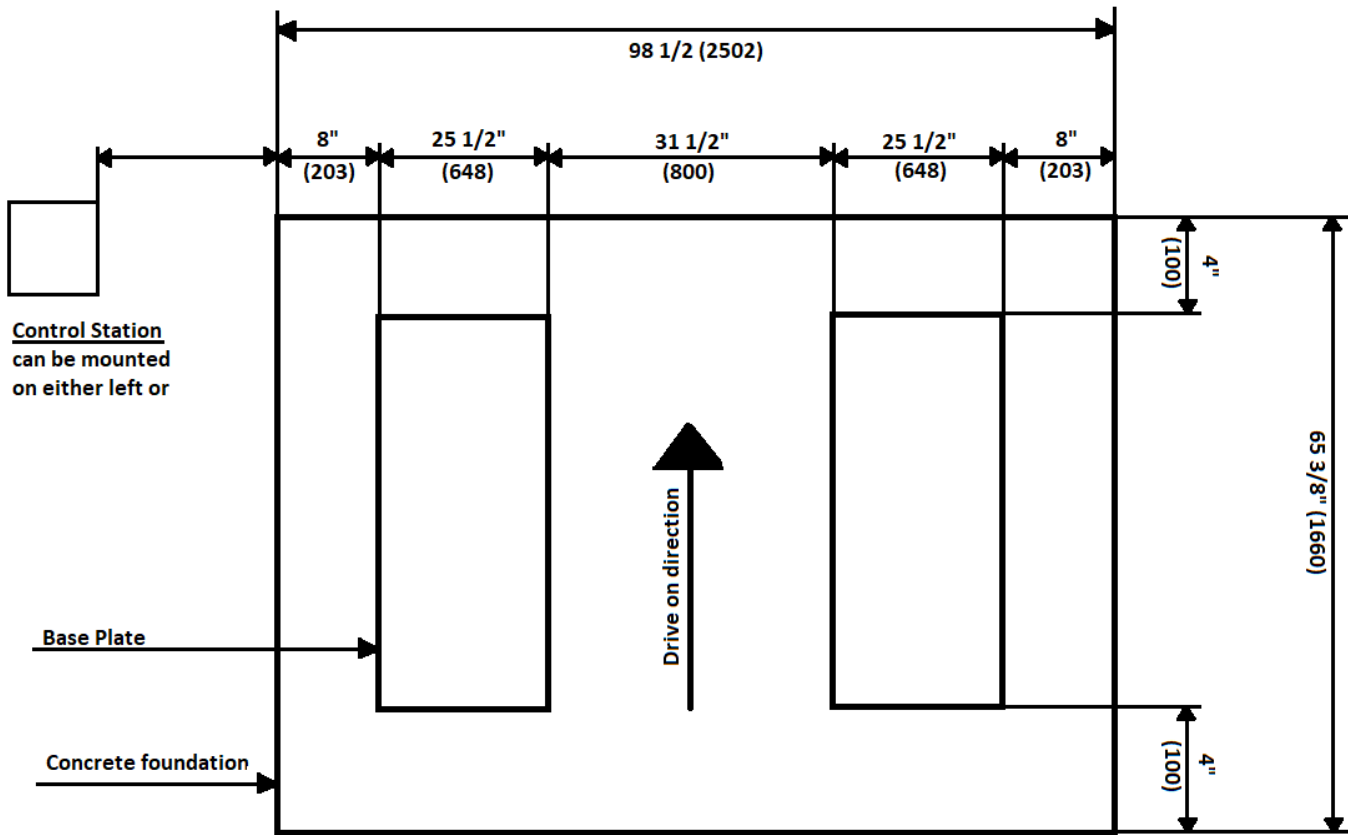

Numbers in ( ) are metric measurements

## Concrete Requirements:

Size: 98 1/2" x 65 3/8" (2502mm x 1660mm)

Thickness: 4" (100mm)

Quality 3500 psi.



# APPENDIX 3: CONCRETE ANCHOR SPECIFICATIONS

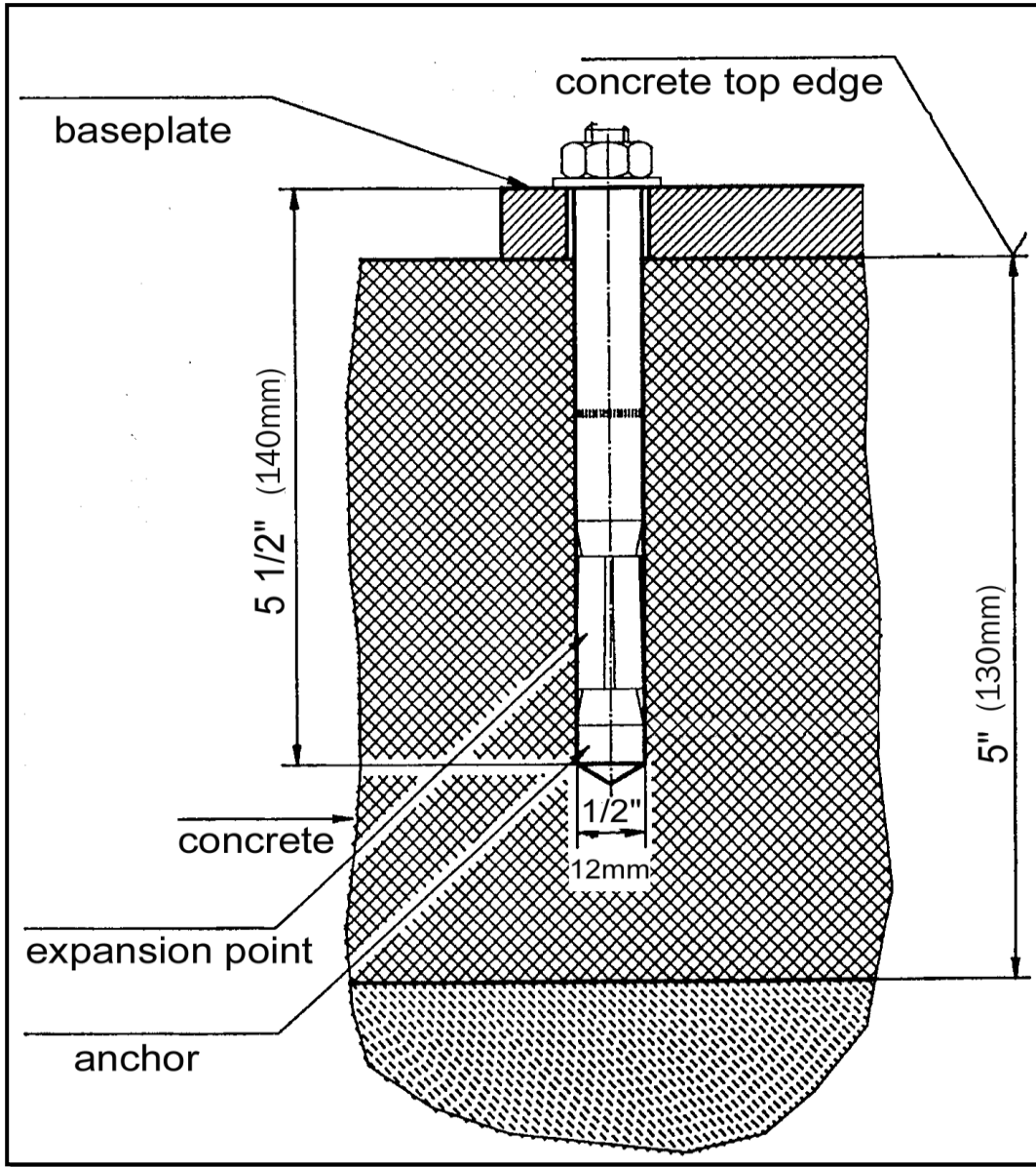

# APPENDIX 4: HYDRAULIC DIAGRAM

Hydraulic plan

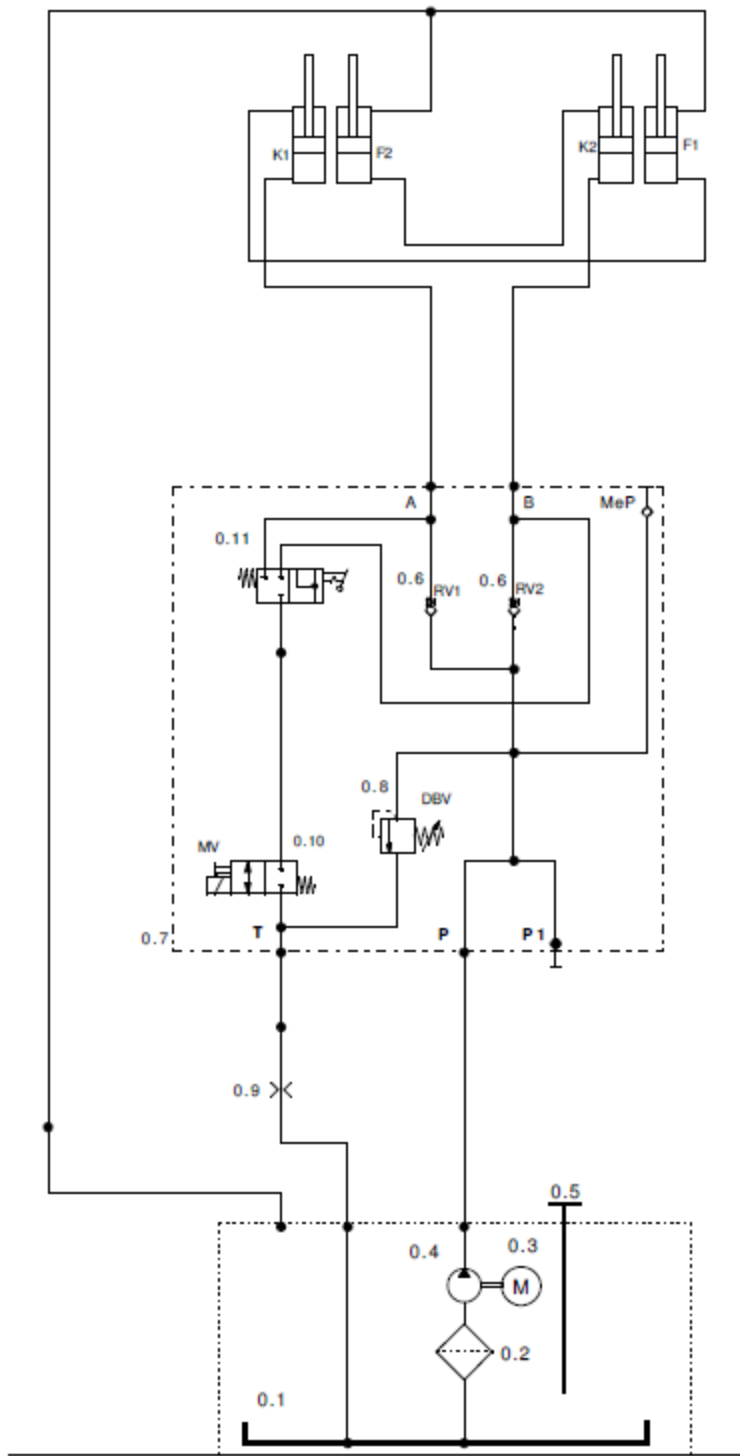

0.1	OIL CONTAINER	0.7	000JL21151	HYDRAULIC BLOCK	
0.2	980012	SUCTION FILTER	0.8	155211	PRESSURE RELIEF VALVE
0.3	992658	MOTOR	0.9		BEZEL D1.5
0.4	980340	MECHANICAL PUMP 2.7 CM <sup>3</sup>	0.10	158641	DOUBLE-ACTING VALVE
0.5	980011	OIL DIPSTICK	0.11	974820	BALL VALVE
0.6	983700	CHECK VALVE			

## 1. Hydraulic Parts List

K1 – Master Cylinder 1

F1 – Slave Cylinder 1

K2 – Master Cylinder 2

F2 – Slave Cylinder 2

MeP - Measuring Port (pressure)

# APPENDIX 5: ELECTRICAL DIAGRAM-230 V SINGLE PHASE

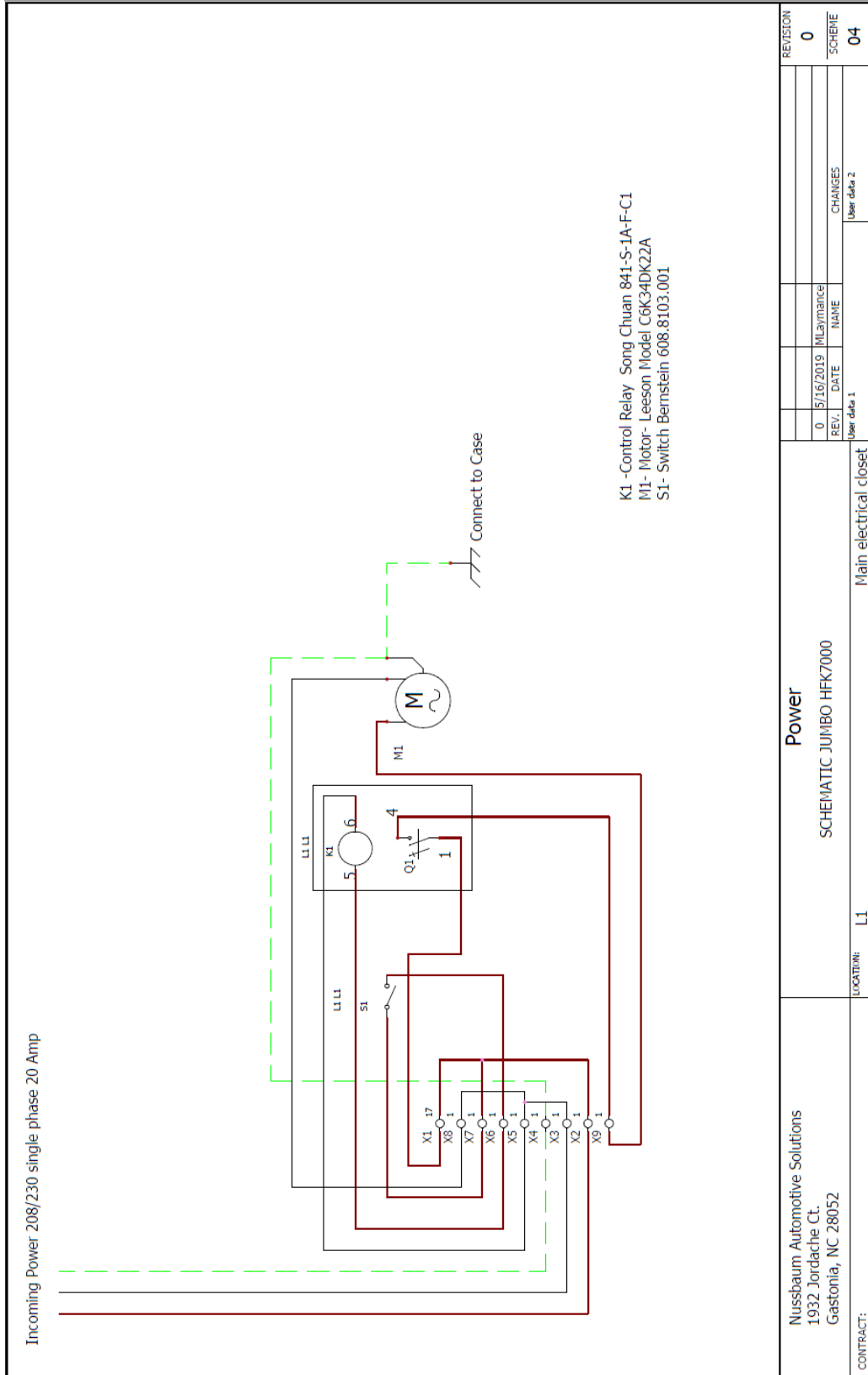

## JUMBO 7000 HF SCISSOR



# APPENDIX 6: FLUSH MOUNT CONCRETE PIT DRAWING

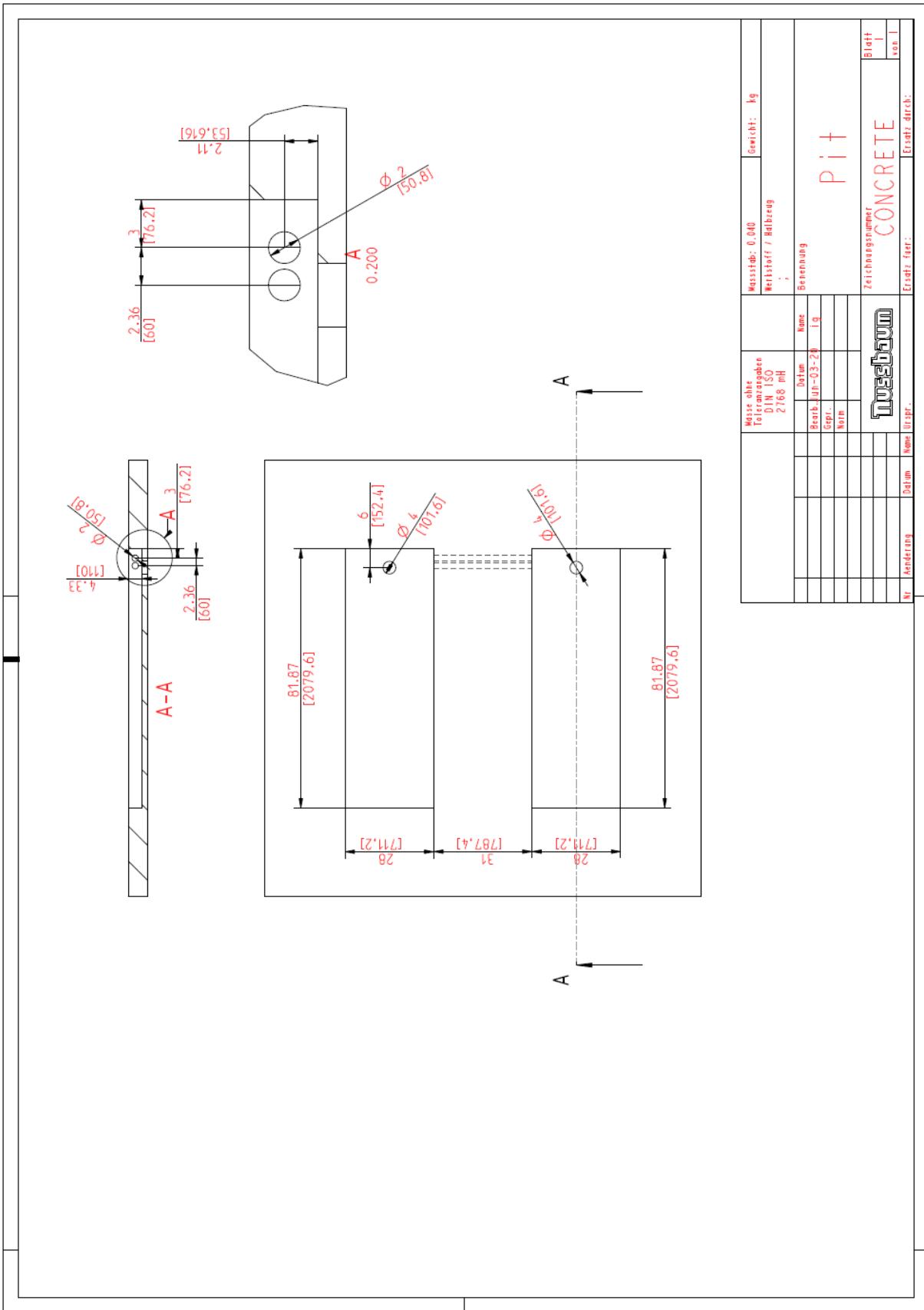



# APPENDIX 8: FLUSH MOUNT INSTALLATION DRAWING 2

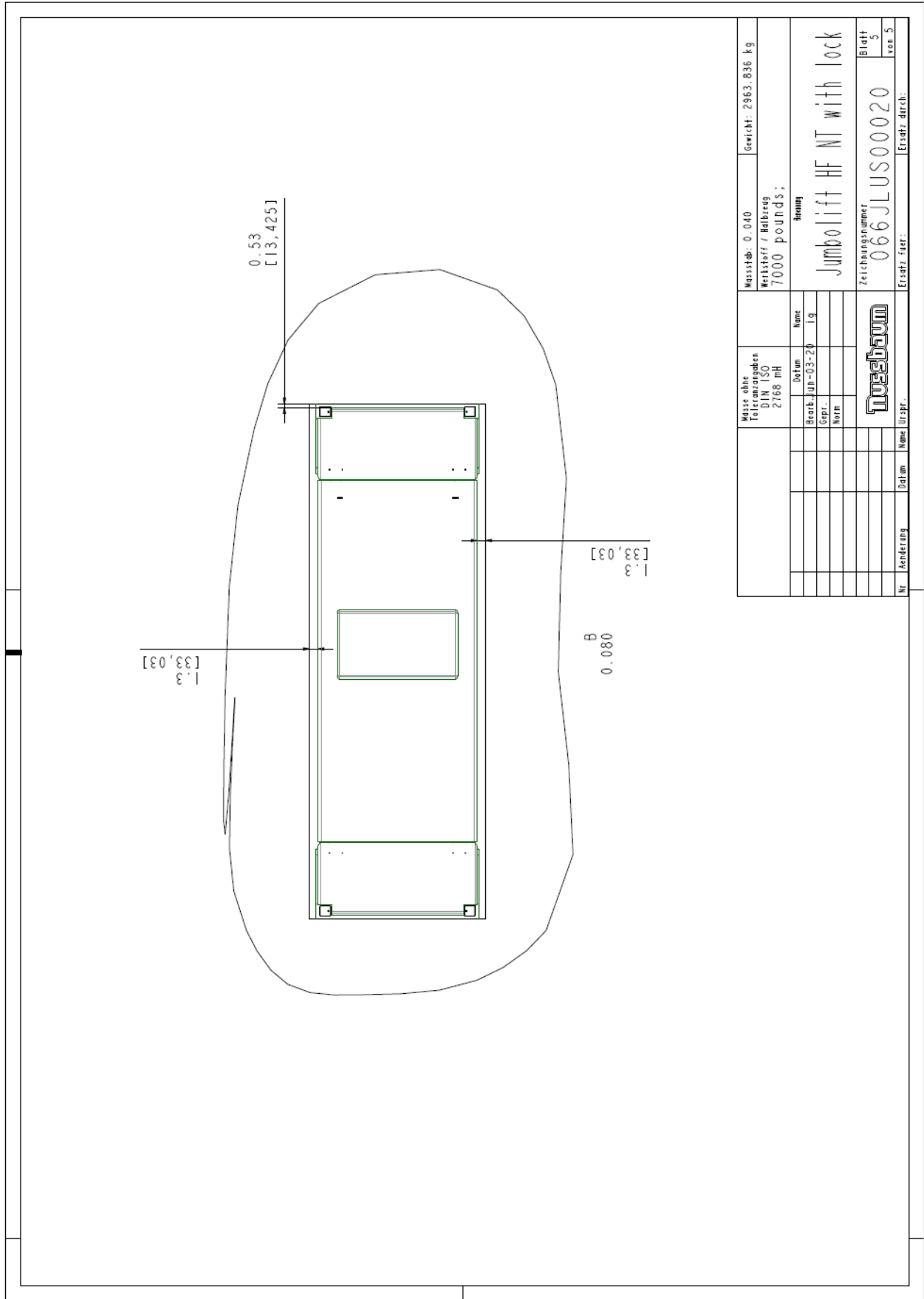

## JUMBO 7000 HF SCISSOR